

PROPRIETARY AND CONFIDENTIAL

THE INFORMATION CONTAINED IN THIS DRAWING IS THE SOLE PROPERTY OF DYTRAN INSTRUMENTS INC. ANY REPRODUCTION IN PART OR AS A WHOLE WITHOUT THE WRITTEN PERMISSION OF DYTRAN INSTRUMENTS INC. IS PROHIBITED

REVISIONS

REV	ECN	DESCRIPTION	BY/DATE	CHK	APPR
B	14121	ADDED 7576A6 TO VARIATION TABLE.	NDC 03/22/18	KG	DV
C	14221	SEE ECN	EM 05/29/18	MH	W

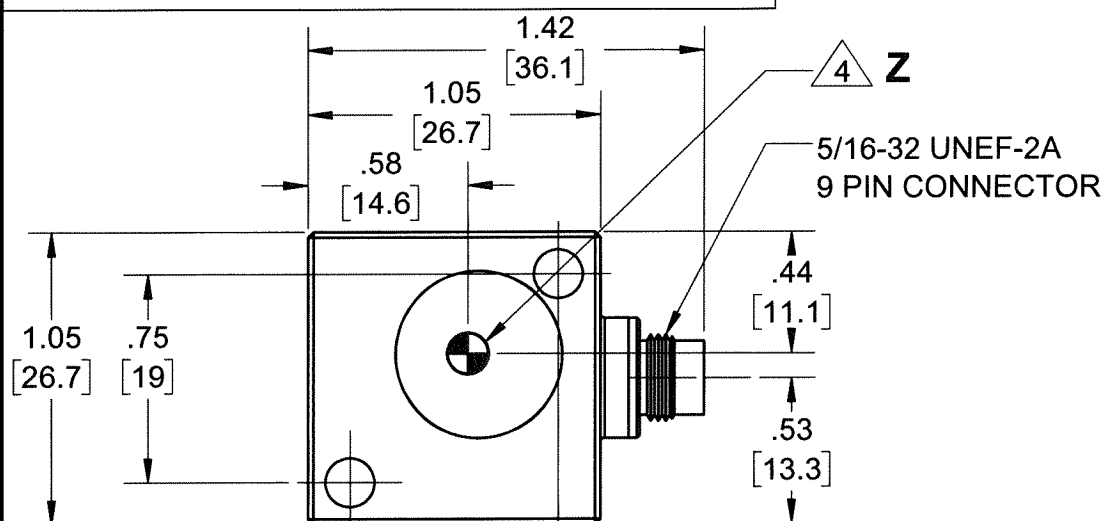

MODEL	GYRO RANGE	ACCELEROMETER RANGE
7576A1	±50°/sec	±5G
7576A2	±150°/sec	±10G
7576A3	±250°/sec	±30G
7576A4	±20,000°/sec	±200G
7576A5	±50°/sec	±2G
7576A6	±150°/sec	±2G

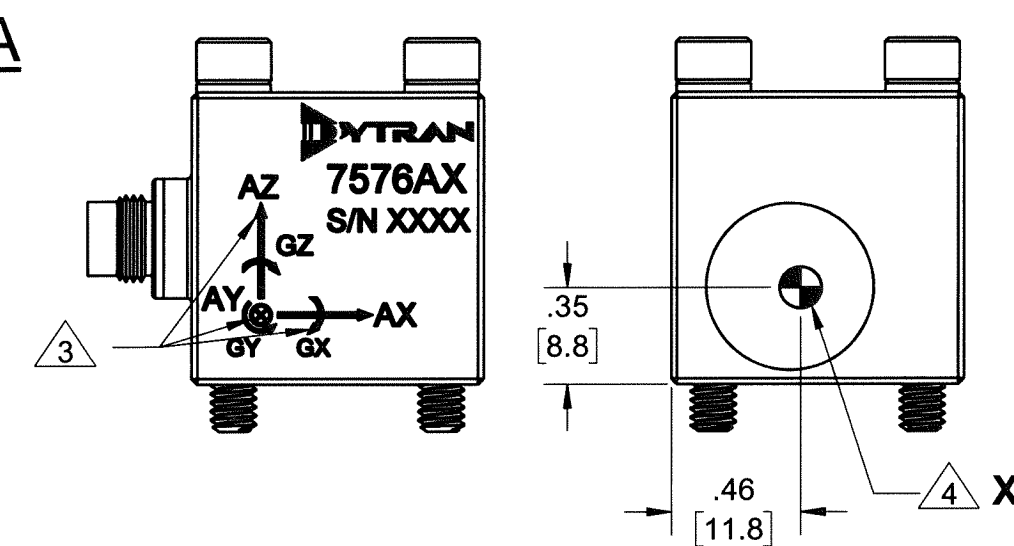
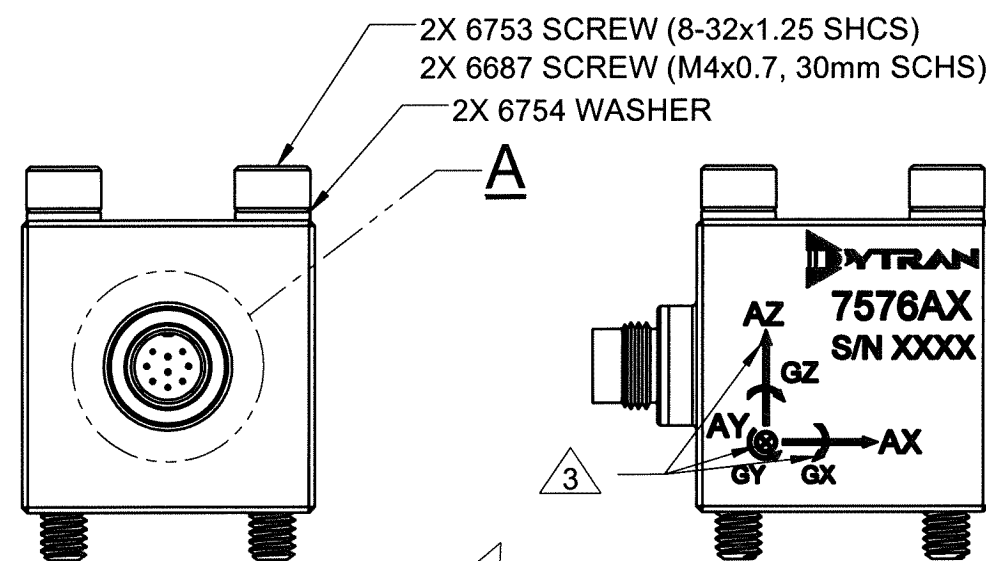
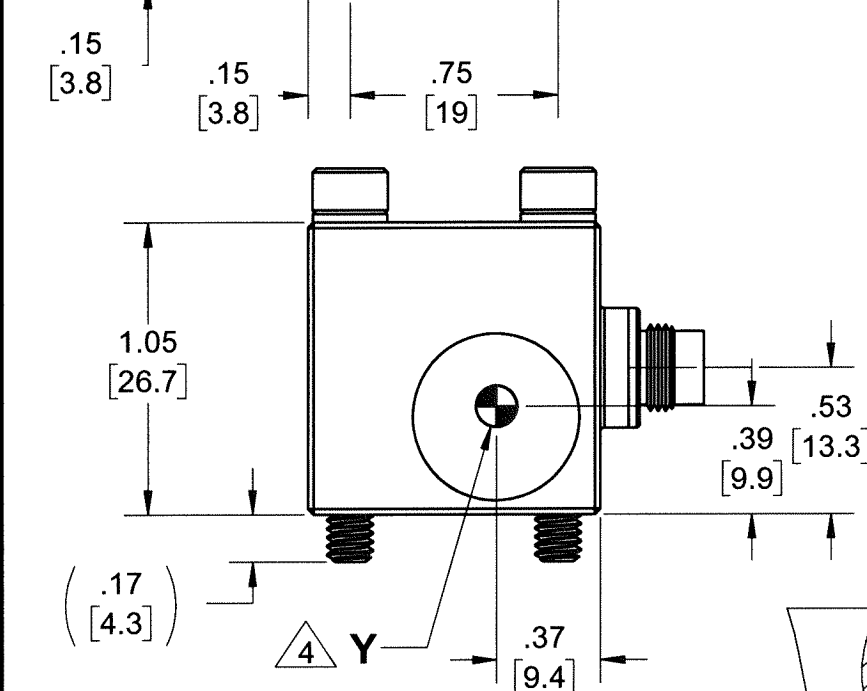
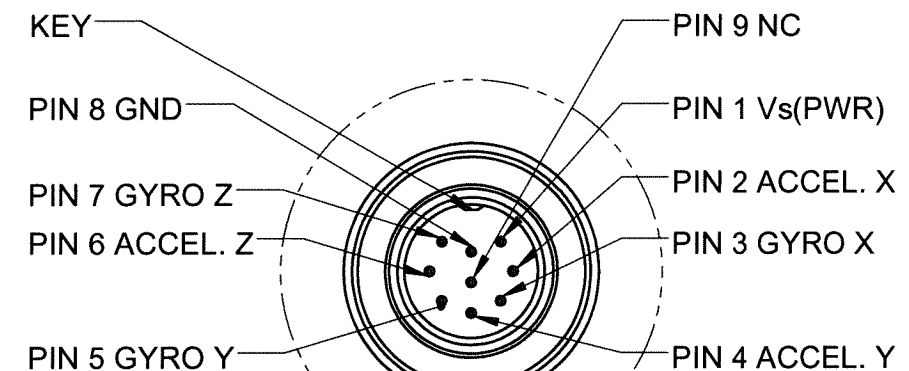

RECOMMENDED MOUNTING PREPARATION:  
 PREPARE FLAT MOUNTING SURFACE,  $\phi$  1.50 [  $\phi$  38.1 ] MIN, FLAT TO .001 TIR.  
 TAP 2X 8-32 UNC-2B  $\nabla$  .45 [ 11.4 ] MIN. (OR 2X M4x0.7  $\nabla$  .45 [ 11.4 ] MIN.)  
 TORQUE TO 10-12 Lb-in. [ 1.12 - 1.35 N-m ]

5 MATES WITH DYTRAN CABLES: - 6964AXX (9-PIN TO FLYING LEADS)  
 - 6445AXX (9-PIN TO 7 BNC PLUGS)  
 (XX DENOTES LENGTH IN FEET)

4 MARKING DENOTES LOCATION OF SENSING ELEMENT'S CENTER OF MASS

3 ARROWS INDICATE GYROSCOPIC & ACCELERATION DIRECTIONS FOR POSITIVE OUTPUT

2. MATERIAL: TITANIUM ALLOY

1. WEIGHT: 25 GRAMS, MAX.

NOTES: UNLESS OTHERWISE SPECIFIED

<small>UNLESS OTHERWISE SPECIFIED:          INTERPRET DIM &amp; TOL PER ASME Y14.5M - 1994.          REMOVE BURRS.          COUNTERSINK INTERNAL THDS 90° TO MAJOR DIA.          CHAM EXT THDS 45° TO MINOR DIA.          THD LENGTHS AND DEPTHS ARE FOR MIN FULL THDS.          DIMENSIONS APPLY AFTER FINISHING.</small>	<small>UNLESS OTHERWISE SPECIFIED:          DIMENSIONS IN BRACKETS [ ] ARE IN MILLIMETERS TOLERANCES ARE:</small>				<b>MASTER ONLY IF IN RED</b> Chatsworth, CA																			
	<small>DECIMALS .XX ±.03 .XXX ±.010</small>	<small>METRIC X ± 0.8 .XX ± 0.25</small>	<small>ANGLES ±1°</small>																					
	<table border="1"> <tr><th>APPROVALS</th><th>DATE</th></tr> <tr><td>ORIG DV</td><td>01/18/16</td></tr> <tr><td>CHK KG</td><td>03/27/18</td></tr> <tr><td>APP DV</td><td>03/28/18</td></tr> </table>	APPROVALS	DATE				ORIG DV	01/18/16	CHK KG	03/27/18	APP DV	03/28/18	<table border="1"> <tr><th>TITLE:</th><td>OUTLINE/INSTALLATION DRAWING, 7576A SERIES</td></tr> <tr><th>SIZE</th><td>B</td></tr> <tr><th>CAGE CODE</th><td>2W033</td></tr> <tr><th>DWG NO</th><td>127-7576A1</td></tr> <tr><th>REV</th><td>C</td></tr> </table>		TITLE:	OUTLINE/INSTALLATION DRAWING, 7576A SERIES	SIZE	B	CAGE CODE	2W033	DWG NO	127-7576A1	REV	C
	APPROVALS	DATE																						
ORIG DV	01/18/16																							
CHK KG	03/27/18																							
APP DV	03/28/18																							
TITLE:	OUTLINE/INSTALLATION DRAWING, 7576A SERIES																							
SIZE	B																							
CAGE CODE	2W033																							
DWG NO	127-7576A1																							
REV	C																							
<small>ALL MACHINED SURFACES.          TOTAL RUNOUT WITHIN .005.          BREAK SHARP EDGES .005 TO .010.          MACHINED FILLET RADII .005 TO .015.          WELDING SYMBOLS PER AWS A2.4.          ABBREVIATIONS PER MIL-STD-12.</small>	<small>DO NOT SCALE DRAWING</small>		<table border="1"> <tr><th>SCALE:</th><td>2:1</td></tr> <tr><th>SHEET</th><td>1 OF 1</td></tr> </table>	SCALE:	2:1	SHEET	1 OF 1																	
SCALE:	2:1																							
SHEET	1 OF 1																							

<b>Model Number</b> 7576A2	<b>PERFORMANCE SPECIFICATION</b>	<b>DOC NO</b> PS7576A2
<b>6DOF VIBRATION SENSOR</b>		REV C, ECN 14974, 03/25/19



- VARIABLE CAPACITANCE TECHNOLOGY
- 6 DEGREES OF FREEDOM MEASUREMENTS
- HERMETICALLY SEALED
- DC RESPONSE
- INTERNATIONAL TRAFFIC IN ARMS REGULATION (ITAR) FREE

**PHYSICAL**

Weight, Max  
 Connector Type  
 Material

ENGLISH		SI	
1.9	oz	55	grams
5/16-32 UNEF-2A		5/16-32 UNEF-2A	
Ti-6Al-4V		Ti-6Al-4V	

**ACCELEROMETER PERFORMANCE**

Input Range  
 Frequency Response (±5%)  
 Frequency Response (±3dB)  
 Scale Factor, Nom. [1]  
 Output Noise, Typ.  
 Non-Linearity, Typ. [2]  
 Temperature Range  
 Scale Factor Temperature Coefficient [3]  
 Axis misalignment, Max.  
 Shock Survivability  
 Resonant Frequency  
 Cross Axis Sensitivity, Max.

±10	g	±98.1	m/s <sup>2</sup>
0-600	Hz	0-600	Hz
0-2500	Hz	0-2500	Hz
235	mV/g	24.0	mV/m/s <sup>2</sup>
0.00004	g rms/√ Hz	0.0004	m/s <sup>2</sup> /√ Hz
0.2	% F.S	0.2	% F.S
-67 to 257	°F	-55 to 125	°C
67	ppm/°F	120	ppm/°C
10	mrad	10	mrad
6000	g	58860	m/s <sup>2</sup>
>2.8	kHz	>2.8	kHz
5	%	5	%

**GYRO PERFORMANCE**

Input Range  
 Frequency Response  
 Sensitivity ±10% [1]  
 Rate noise density, Typ.  
 Non-Linearity, Typ [2]  
 Temperature Range  
 Resonant Frequency  
 Cross Axis Sensitivity, Max.

±150	°/sec	±150	°/sec
1-3000	Hz	1-3000	Hz
12.5	mV/°/sec	12.5	mV/°/sec
0.04	(°/sec)/√ Hz	0.04	(°/sec)/√ Hz
0.2	% F.S	0.2	% F.S
-40 to 221	°F	-40 to 105	°C
14.5	kHz	14.5	kHz
5	%	5	%

**ELECTRICAL**

Output Impedance, Nom  
 Operating Voltage  
 Output Bias Voltage ±0.5 VDC  
 Operating Current  
 Power Supply Rejection Ratio

Typical  
Max

2	Ω	2	Ω
6 to 14	VDC	6 to 14	VDC
2.5	VDC	2.5	VDC
23	mA DC	23	mA DC
28	mA DC	28	mA DC
>65	dB	>65	dB

**ENVIRONMENTAL**

Storage Temperature  
 Seal

-67 to 257	°F	-55 to 125	°C
Hermetic		Hermetic	

**This family also includes:**

Model	Input Range (EU) Accel/Gyro	Frequency response (Hz) Accel./Gyro	Sensitivity, ±10% (mV/EU) Accel/Gyro	Max.Shock (0.1ms), g	Noise (EU/√Hz) Accel./Gyro
7576A1	±5 / ±50	0-1300 / 1-1000	470 / 25	6000	0.00004 / 0.04
7576A3	±30 / ±250	0-3000 / 0.01-2500	78.33 / 7	6000	0.000089 / 0.06
7576A4	±200 / ±20000	0-3800 / 0-2000	11.75 / 0.1	6000	0.0009 / 0.25
7576A5	±2 / ±50	0-1150 / 1-1000	1175 / 25	6000	0.000088 / 0.04

Refer to the performance specifications of the products in this family for detailed description.

**Supplied Accessories:**

- 1) Accredited calibration certificate (ISO 17025)
- 2) Mounting screw model 6753, 8-32 UNF-2A, qty 2
- 3) Mounting washer model 6754, qty 2
- 4) Mounting screw model 6687, M4 X 0.7, qty 2

**Notes:**

- [1] Measured using Earth gravity
  - [2] Best fit zero based line method
  - [3] Over the rated temperature range.
  - [4] In the interest of constant product improvement, we reserve the right to change specifications without notice.
- It is the customer's responsibility to validate that a particular product with the properties described in the product specification is suitable for use in a particular application. Parameters provided in datasheets and / or specifications may vary in different applications and performance over time. All operating parameters, including typical parameters, must be validated for each customer application by the customer's technical experts.

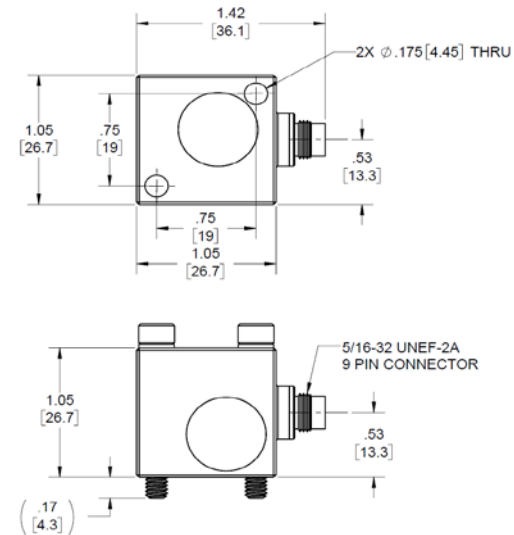

Units on the line drawing are in inches. Refer to 127-7576A1 for more information.



21592 Marilla Street, Chatsworth, California 91311 Phone: 818.700.7818 Fax:818.700.7880 www.dytran.com  
 For permission to reprint this content, please contact info@dytran.com